

200 SERIES stepper motor pump without driver

Williamson
UK manufacturers of quality peristaltic pumps

- Long Life Brushless Motor
- Various Tube Materials/Sizes
- 2,3,4 or 6 Rollers
- Integral Tube Grips



The 200 series stepper driven peristaltic pump offers a compact & reliable means of dosing a wide range of liquids. They are available in various configurations of tubing type & size giving flow rates of between 0.1 & 1.32 ml/rev.

The pump head is designed to be disposable but is assembled using a single screw enabling dis-assembly & re-assembly for tube changing if required.

DIMENSIONS (mm)

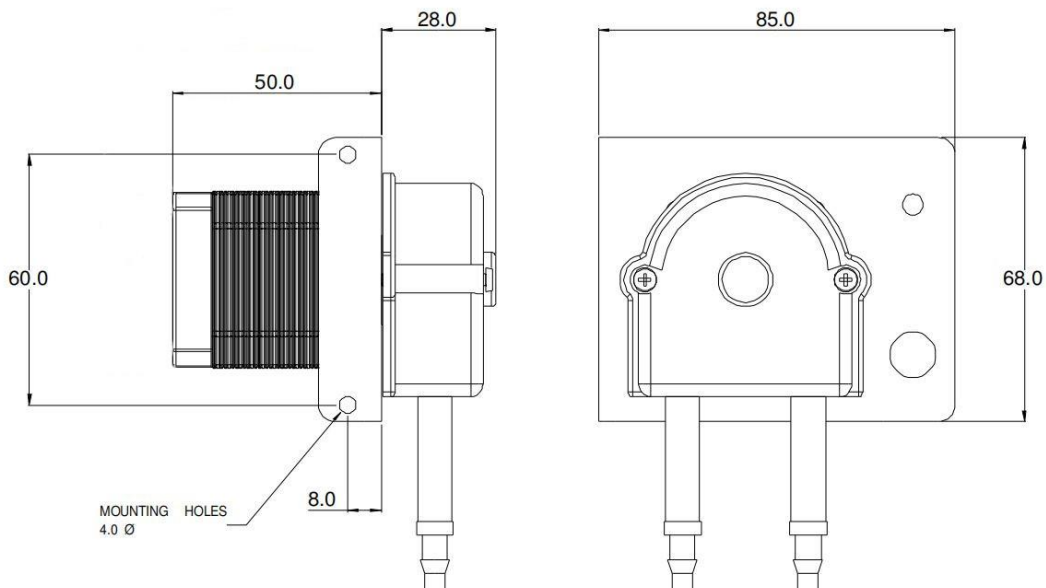

The Williamson Manufacturing Company Ltd provides no warranty on usage of pumps. We recommend that life tests be carried out prior to use. This information is given in good faith and believed to be correct at the time of publishing. The Williamson Manufacturing Company Ltd cannot accept responsibility for inaccuracy or any errors contained herein. Copyright the Williamson Manufacturing Company Ltd 2008.



Williamson Manufacturing Co Ltd
Unit 2, Centenary Industrial Estate
Hughes Road
Brighton
East Sussex BN2 4AW UK
Email: sales@williamsonpumps.co.uk

www.wmcpumps.com

+44(0)1273 857752

200 SERIES stepper motor pump without driver

Devise your product code by using codes from the table on the right where stated below.

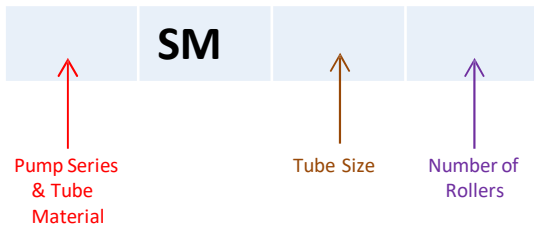

202-SM-016/3

Example product code for 200 series pump head fitted with Viton® tubing, stepper motor, 1.6mm ID tubing & 3 rollers

	Product code
Pump series and tube material	
Silicone (Peroxide Cured)	200
Tygon® A60F Norprene (Food Grade)	201
Viton®	202
Tygon A60G	205
Tygon Chemical® Norprene (3mm & 5mm only)	207
Tube Size (bore) mm	
1.6	-016
3.0	-030
3.0	-050
Number of rollers	
2	/2
3 (Supplied as standard)	/3
4	/4
6	/6

Stepper Motor Specification

Step Angle	1.8 Degrees
Step Angle Accuracy.	5%
Phase Current	1.5 A
Phase resistance	2 ohms
Phase inductance	3.85 mH
Detent torque	2.4 Ncm
Rotor inertia	82 g/cm ²
Insulation class	B
Number of leads	4

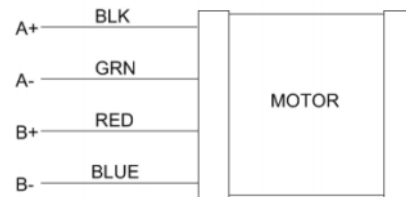

MOTOR ONLY

Flow Rates ml per revolution

Flow rates based on silicone tubing. Flow rates for Tygon A60F® will be approx. 10% less, Tygon Chemical® & Viton® will be 20-25% less.

No of Rollers	1.6 ID tube	3.0 ID tube	5.0 ID tube
2	0.22	0.64	1.32
3	0.20	0.59	1.18
4	0.17	0.5	0.94
6	0.14	0.32	0.6

Flow rates for guidance only and subject to tube tolerance, tube age, fluid viscosity & back pressure.

The Williamson Manufacturing Company Ltd provides no warranty on usage of pumps. We recommend that life tests be carried out prior to use. This information is given in good faith and believed to be correct at the time of publishing. The Williamson Manufacturing Company Ltd cannot accept responsibility for inaccuracy or any errors contained herein. Copyright the Williamson Manufacturing Company Ltd 2008.



Williamson Manufacturing Co Ltd
Unit 2, Centenary Industrial Estate
Hughes Road
Brighton
East Sussex BN2 4AW UK
Email: sales@williamsonpumps.co.uk